

EXPLODED VIEW & PARTS LISTING

Air Operated Double Diaphragm Pump

Model: DP-40BP[x]-HD (XDP)
Polypropylene Series



To Purchase:

- ☎ 800-990-7867
- ✉ sales@yamadapump.com
- 📍 Find My Rep

More Information:

- ▶ YouTube: @yamadapump
- 🌐 yamadapump.com
- Data Sheets | CAD Drawings | Manuals Literature | BOM | Performance Curves*

Trial Program

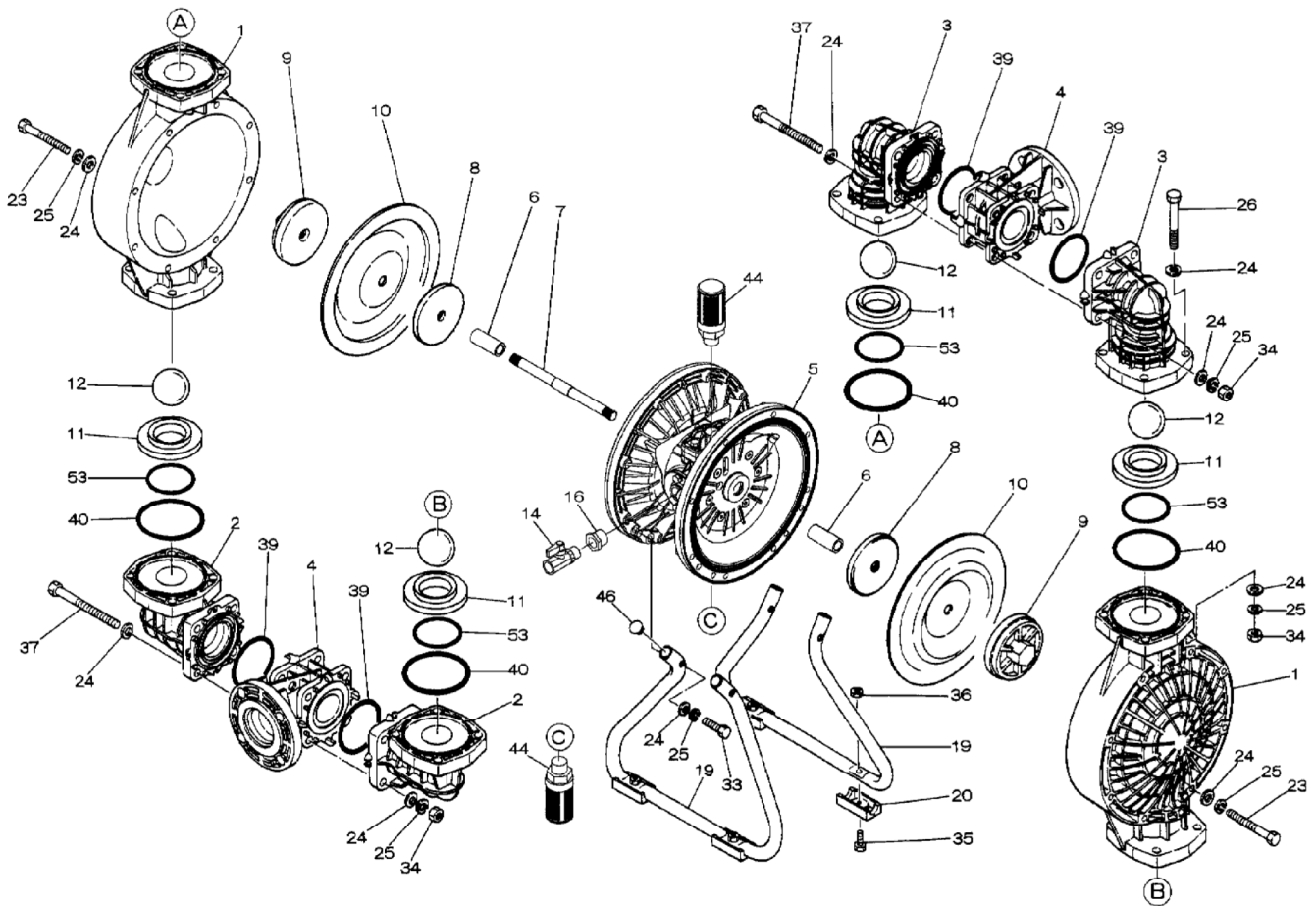

Air Operated Double Diaphragm Pump

804770 Center Body Assembly

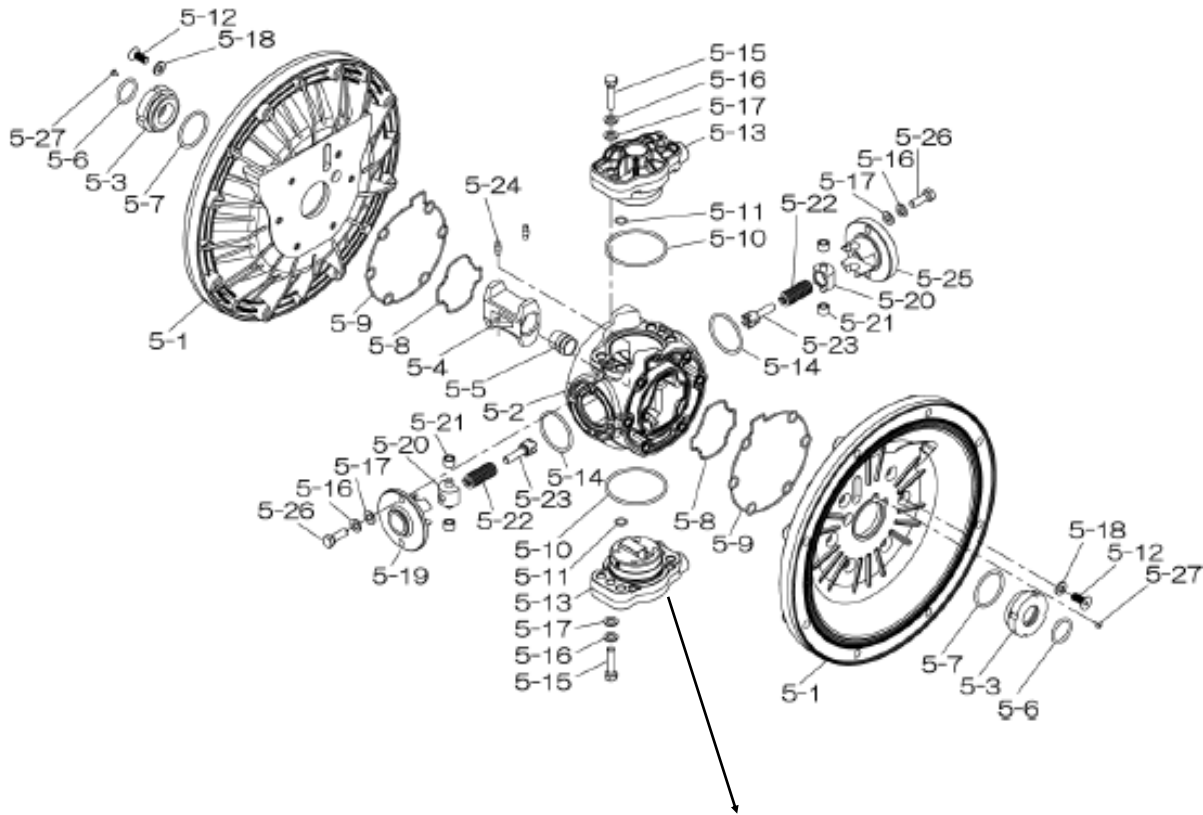

804784 Valve Body Assembly

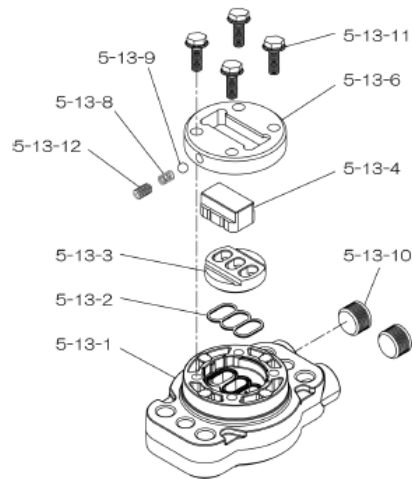

Air Operated Double Diaphragm Pump

	DP-40BPC-HD	DP-40BPN-HD	DP-40BPE-HD	DP-40BPV-HD	DP-40BPH-HD	DP-40BPS-HD			
	854395	854396	854397	854398	854400	854401			
REF. NO.	PART NO.	PART NO.	PART NO.	PART NO.	PART NO.	PART NO.	DESCRIPTION	QTY.	REORDER
1	780147	780147	780147	780147	780147	780147	OUT CHAMBER	2	
2	780244	780244	780244	780244	780244	780244	IN MANIFOLD	2	
3	780150	780150	780150	780150	780150	780150	OUT MANIFOLD	2	
4	780248	780248	780248	780248	780248	780248	CENTER MANIFOLD	2	
5	804770	804770	804770	804770	804770	804770	CENTER BODY ASSY	1	
5-1	716215	716215	716215	716215	716215	716215	AIR CHAMBER	2	
5-2	716256	716256	716256	716256	716256	716256	BODY	1	
5-3	773048	773048	773048	773048	773048	773048	THROAT BEARING	2	
5-4	716214	716214	716214	716214	716214	716214	SHUTTLE	1	
5-5	773047	773047	773047	773047	773047	773047	CENTER ROD GUIDE	1	
5-6	640023	640023	640023	640023	640023	640023	O-RING	2	
5-7	640133	640133	640133	640133	640133	640133	O-RING	2	
5-8	773040	773040	773040	773040	773040	773040	GASKET	2	
5-9	773041	773041	773041	773041	773041	773041	GASKET	2	
5-10	640138	640138	640138	640138	640138	640138	O-RING	2	
5-11	640007	640007	640007	640007	640007	640007	O-RING	8	
5-12	683812	683812	683812	683812	683812	683812	FLAT SOCKET	12	
5-13	804784	804784	804784	804784	804784	804784	VALVE BODY ASSY	2	
5-13-1	716244	716244	716244	716244	716244	716244	VALVE BODY	1	
5-13-2	773042	773042	773042	773042	773042	773042	GASKET	2	
5-13-3	716246	716246	716246	716246	716246	716246	SEAT	1	
5-13-4	773425	773425	773425	773425	773425	773425	BLOCK	1	
5-13-6	773426	773426	773426	773426	773426	773426	GUIDE PLATE	1	
5-13-8	706612	706612	706612	706612	706612	706612	SPRING INK	1	
5-13-9	686271	686271	686271	686271	686271	686271	BALL	1	
5-13-10	772934	772934	772934	772934	772934	772934	PLUG	2	
5-13-11	602300	602300	602300	602300	602300	602300	TAPPING BOLT	4	
5-13-12	610025	610025	610025	610025	610025	610025	HEX SOCKET HEAD SCREW	1	
5-14	640134	640134	640134	640134	640134	640134	O-RING	2	
5-15	611153	611153	611153	611153	611153	611153	BOLT HEX FT	4	
5-16	631420	631420	631420	631420	631420	631420	SPRING WASHER	8	
5-17	631013	631013	631013	631013	631013	631013	FLAT WASHER	8	
5-18	684987	684987	684987	684987	684987	684987	WASHER	12	
5-19	716249	716249	716249	716249	716249	716249	RETAINER	1	
5-20	713620	713620	713620	713620	713620	713620	SPRING GUIDE	2	
5-21	773067	773067	773067	773067	773067	773067	BUSH	4	
5-22	684537	684537	684537	684537	684537	684537	SPRING	2	
5-23	714446	714446	714446	714446	714446	714446	TRIP ARM	2	
5-24	700231	700231	700231	700231	700231	700231	PIN	2	
5-25	716216	716216	716216	716216	716216	716216	RETAINER	1	
5-26	611149	611149	611149	611149	611149	611149	BOLT	4	
5-27	686337	686337	686337	686337	686337	686337	TAPPING SCREW	2	
6	716219	716219	716219	716219	716219	716219	CENTER BUSH	2	
7	716218	716218	716218	716218	716218	716218	CENTER ROD	1	
8	711902	711902	711902	711902	711902	711902	CENTER DISK 40-R	2	
9	771725	771725	771725	771725	771725	771725	CENTER DISK 40PP-R	2	
10	771853	771700	771854	771799	771701	771975	DIAPHRAMG	2	
11	772096	772096	772086	772096	772096	772096	VALVE SEAT	4	
12	770550	770584	770593	770602	773142	773172	BALL	4	
14	686972	686972	686972	686972	686972	686972	BALL VALVE	1	
16	684339	684339	684339	684339	684339	684339	BUSHING	1	

Air Operated Double Diaphragm Pump

	DP-40BPC-HD	DP-40BPN-HD	DP-40BPE-HD	DP-40BPV-HD	DP-40BPH-HD	DP-40BPS-HD			
	854395	854396	854397	854398	854400	854401			
REF. NO.	PART NO.	PART NO.	PART NO.	PART NO.	PART NO.	PART NO.	DESCRIPTION	QTY.	REORDER
19	711925	711925	711925	711925	711925	711925	STAND	2	
20	771865	771865	771865	771865	771865	771865	FOOT RUBBER	4	
23	686156	686156	686156	686156	686156	686156	BOLT	16	
24	631330	631330	631330	631330	631330	631330	FLAT WASHER	68	
25	680257	680257	680257	680257	680257	680257	SPRING WASHER	44	
26	621183	621183	621183	621183	621183	621183	BOLT	16	
33	621179	621179	621179	621179	621179	621179	BOLT	4	
34	628013	628013	628013	628013	628013	628013	NUT	24	
35	621149	621149	621149	621149	621149	621149	BOLT	4	
36	683837	683837	683837	683837	683837	683837	NUT W/ FLANGE	4	
37	683542	683542	683542	683542	683542	683542	BOLT	8	
39	640060	640060	683998	642060	640060	683998	O-RING	4	
40	640064	640064	684121	642064	640064	648121	O-RING	4	
44	804697	804697	804697	804697	804697	804697	MUFFLER	2	
46	683641	683641	683641	683641	683641	683641	CAP	4	
53	640136	640136	685447	642136	640136	685447	O-RING	4	
KIT	K40-PC	K40-PN	K40-PE	K40-PV	K40-PH	K40-PS	LIQUID SIDE		
KIT	K45-AM-DP-HD						AIR MOTOR		

General Tools:

- Socket wrench - 24mm
- Hexagonal box wrench - 5mm, 6mm
- Small crowbars - 2 (B_C, B_N, B_E, B_V)
- Open-end wrenches - 19mm, 24mm
- Phillips head screw driver

Special Tools:

- Socket (804129) for a guide to remove the throat bearing (sold separately)

Miscellaneous:

- Assembly Oil - Turbine oil class 1 (equivalent to ISO VG32 grade)
- Nuts - M16 x 1.5
- Thread locker
- Urea grease grade (NLGI) No. 2, Shell Alvania Grease S1

Torque Requirements:

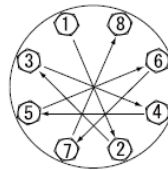

Tightening torque for center rod and out chambers.

Center Rod 36 ft-lbf {50 N-m}
Out Chambers 26 ft-lbf {35 N-m}

Tightening torque for manifold retainer bolts.

BP[x]-HD 15 ft-lbf {20 N-m}

Customer Notes

Model #: _____
 Description: _____
 Serial #: _____
 Date Installed: _____
 Department Location: _____
 Tag/Project: _____